

Operating and Maintenance Instructions for Automatic Air and Vacuum Valve for Waste Water 150 PSI / PN 10 Model 989



1. Intended use

The H-TEC automatic air and vacuum valve, Model 989, is used for aerating and de-aerating of pressure pipe line systems for a pressure range between 0 – 150 psi (0 - 10 bar), as well as in vacuum systems. The Medium: domestic waste water (industrial or domestic waste water with a high content of acid or alkali only on consultation).

Please note: this product must be maintained at least once per year, and even more frequently in case of waste water pressure lines with a high degree of contamination or a tendency to saponify. Please, observe carefully also the applicable national standards and general regulations for the prevention of accidents.

Air and vacuum valves contain compressed air. Therefore, isolate the air and vacuum valve from the operating system. Before starting any maintenance work the valve must be depressurized via the ball valve!

2. Product description

The H-TEC automatic air and vacuum valve is an two-way air valve, both aerating and removing air enclosed in pipelines. The valve operates automatically and is designed to reduce water hammers. The seat of this air valve is not in contact with the medium. The air and vacuum valve is rated for a maximum operating pressure 150 psi (10 bar).

3. Installation

The air and vacuum valve, Model 989, must be installed in vertical position on a vertical outlet on top of the pressure pipeline (avoid angular installation of any H-TEC automatic air and vacuum valve!). Installation should be as close to the pipeline as possible to reduce the danger of freezing. Note: The lateral arrangement of air valves may considerably influence the control behaviour of the valve. Moreover, in case of heavy contamination there may be problems in the pipeline area upstream of the air valve. A laterally displaced arrangement of air valves shall be avoided.

There must always be a shut-off facility below the air and vacuum valve to allow maintenance work. This automatic valve is intended for installation in shafts. Please, observe the applicable standards and guidelines for this shaft, especially the regulations for the prevention of accidents in case of access to the shaft.

At the air relief outlet of the H-TEC air and vacuum valve a pipe can be connected. Note that the connection of a vent line may possibly influence the control behaviour of the air valve. The same applies to any odour filters that may be installed additionally. In this case it is important to use sufficiently large components to avoid backwater in the valve.

4. Start-up and pressure testing

During pressure testing of new pipeline systems air valves should be generally isolated. To this end the shut-off facility below the valve shall be closed. There is always some residual air enclosed even in a properly vented pipeline. If the air valve is placed correctly, this residual air is carried to the valve possibly causing it to blow off during pressure testing. As a consequence the pipeline system is wrongly assumed to be leaking. Air valves are tested by the manufacturer so that they need not be included in the pressure testing. After completion of pressure testing of the pipeline the shut-off facility is opened slowly and the air valve and its connections are visually inspected under operating pressure. For filling the pipelines please make sure not to exceed the maximum filling rates. Before filling the pipelines it should be checked if the vent holes of the air shafts concerned are actually free. If necessary, the covers should be opened.

Note: Before scavenging a pipe line section with compressed air the valve should be put out of service.

5. Service – maintenance of automatic air and vacuum valve, Model 989

The reliability of the H-TEC automatic air and vacuum valve can be considerably increased by checking it for possible contamination at regular intervals. **Make sure to isolate the air valve from the pipeline system before starting any maintenance work by closing the shut-off valve and to reduce any overpressure possibly existing in the air valve via the ball valve of the flushing line.**

Due to its design the H-TEC automatic air and vacuum valve is well protected against deposits. Nevertheless, depending on the properties of the medium, the operability of the valve should be checked at regular intervals and possible contamination should be removed, especially in case of larger bodies of dirt that cannot be flushed out via the lateral flushing connections.

All maintenance work at H-TEC automatic air and vacuum valves should be performed by personnel which either is trained or read this manual!

Caution: Before enter a manhole take care about all safety regulations for working in manholes, dangerous gases can be found within these buildings. We strongly recommend to fulfil all recommended precautionary measures while working in manholes.

Also we recommend the first maintenance to be done after a period of approx. 4 – 8 weeks and to define further maintenance intervals on the basis of the result of this first maintenance. To this end open the valve according to the below description.

In the course of maintenance, check also the ball valve and all other components for leakage and proper functionality.

Procedure:

1. Unscrew the outlet elbow



2. Unscrew bolts of body.



3. Turn upper body part counter clockwise and dismantle the part and the function unit by pulling from the mechanism

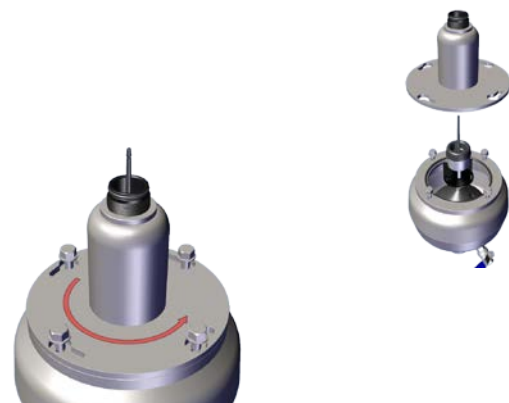



4. Pull out the function unit

5. Clean the body and all parts, especially rinse out the slots of the upper valve cage.

6. Remove the diaphragm from the cup and clean it with clear water. Check the diaphragm for damages. In case of any damage, or worn out signs, the rubber diaphragm must be replaced by a new one.

Assembly of the diaphragm:

1. Pull the diaphragm over the diaphragm holder cup and check the correct placement of the diaphragm within the groove of the cup.

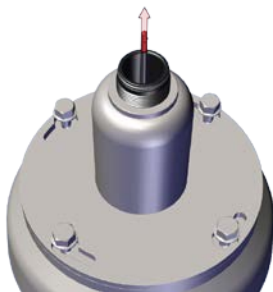

**2. Assembly of the diaphragm within the upper air valve part:
Put the end of the rubber string through the bore hole of the upper air valve part. Pull the string upwards until the wider part of the rubber string moves through the bore hole. You either can hear or feel this final step. Diaphragm is in place now.**

3. The rest of the assembly follows the steps vice versa 4 through 1 of this manual. Visual check of all connections and flushing openings. Leakage test is required!