

Automatic Air and Vacuum Valve for Waste Water

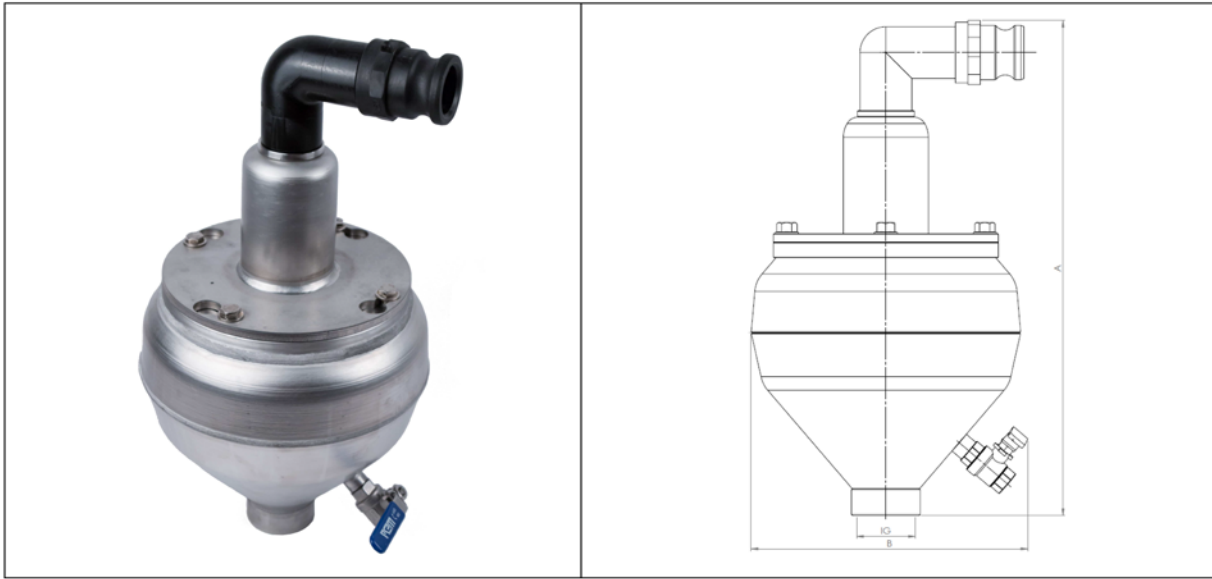

Model 989

Automatic air release and vacuum valve, short body, ss 316,
for operating ranges: 0 – 150 PSI (10 Bar),
outdoor application possible



| Type | Size ANSI | Range Of Pressure PSI/Bar | Overall Height A Inch/mm | Overall Width B Inch/mm | Weight lbs./Kg |
|--------|--------------|------------------------------------|--|---|---------------------|
| Thread | 2" FNPT | 0 – 150 PSI 0 – 10 Bar | 18.9" 480 mm | 10.4" 265 mm | 21.6 lbs. 9.8 Kg |

Features:

Automatic and infinitely variable air valve for waste water applications.
Recommended for outdoor application in frost-free areas.
Maximum Operating Pressure: 150 PSI (10 Bar)
Operating Range: 0 – 150 PSI (0 - 10 Bar)
Valve body of stainless steel 316
Valve seat does not contact the medium (air cushion).
All mechanical parts are manufactured of corrosion-resistant materials.

Valve Maintenance:

Air valves must be tested for function and maintained at least once per year.

Automatic Air and Vacuum Valve for Waste Water



Materials:

| No. | Component | Material |
|-----|--------------------------|----------------------|
| 1 | Body | Stainless Steel, 316 |
| 2 | Cup seal, Diaphragm | MNPT |
| 3 | Float | Polypropylen (PP) |
| 4 | Hex Head Bolt | Stainless Steel, 316 |
| 5 | Outlet elbow with screen | Polyethylene (PE) |

Infinitely variable surge protection

In general understanding the surge protection of an ARV is a measure taken to protect the pipeline system. Filling of the pipeline should be within international standards to prevent water hammer (5ft/s) or (0,25m/s) and correct opening and closing of valves is fundamental.

The design of the H-TEC model 989 ARV allows for large volumes of air (in/out). The unique function for infinite air release/intake, due to the automatic movements of the diaphragm in operation modus, (e.g. fluid level rises, diameter of orifice is reducing infinitely variable) soft sealing and slowing the water column preventing water hammer.

Traditional ARV's operate with two functions: open or closed. The rubber diaphragm of the H-TEC model 989 is infinitely variable operating. In case of increased velocity in the valve the float will lift slow and throttle down the air flow. This function slows the water column, water hammer from this ARV will not occur. The H-TEC model 989 ARV has an integrated pressure spring on the vertical shaft attached to the float. This mechanical feature protects from vibrations, smooth function, prevents amplified movements. No additional surge prevention unit necessary.

